

PETITION TO VACATE PLATTED PUBLIC STREET AND/OR ALLEY

TO THE PLANNING & ZONING COMMISSION AND BOARD OF SUPERVISORS OF CERRO GORDO COUNTY, IOWA:

The undersigned ask that a street and/or alley ² 20 feet wide, commencing at
1.) 1st Street in Owentownship - Cartersville
2.) Cleveland St

and running thence 1) East
2) South

and terminating at 1) 2nd St. Cartersville
2) alley running East from 1st St. to
2nd St. (All in Block 2)

be vacated.

The following information is attached to this petition:

- A plat showing the location of the street and/or alley to be vacated.
- Filing fee in the amount of \$100. (Check made payable to Cerro Gordo County)

By filing this petition, the undersigned land owner(s) certify and/or agree to the following:

- There are no building encroachments on the street and/or alley to be vacated.
- There are building encroachments on the street and/or alley to be vacated, and a detailed survey showing the encroachments is attached.
- Public utility easements exist and if the street and/or alley is vacated, we will provide the utility company with a private easement.

Private easements exist and if the street and/or alley is vacated, we will provide a private easement.

If the street and/or alley is vacated, we understand each of us, along with any mortgagees, will need to file with the county an instrument of consent and description. We understand in order to obtain the "description" a survey will need to be done showing each individual portion of the street and/or alley to be joined to each individual adjacent platted lot.

Owner Signature	Printed Name of Owner	Mailing Address of Owner
<i>Marv Gumbatz</i>	Marv Gumbatz	22098 170 th St. Rockwell, IA
<i>Frank Hanig</i>	Frank Hanig	7042 2nd St Rockwell, IA
<i>Jean Hanig</i>	Hanig Construction	7042 2nd St. Rockwell, IA
<i>Marv Gumbatz</i>	<i>Marv Gumbatz</i>	22098 170 th St Rockwell IA.

202

-005

FRONT ST.

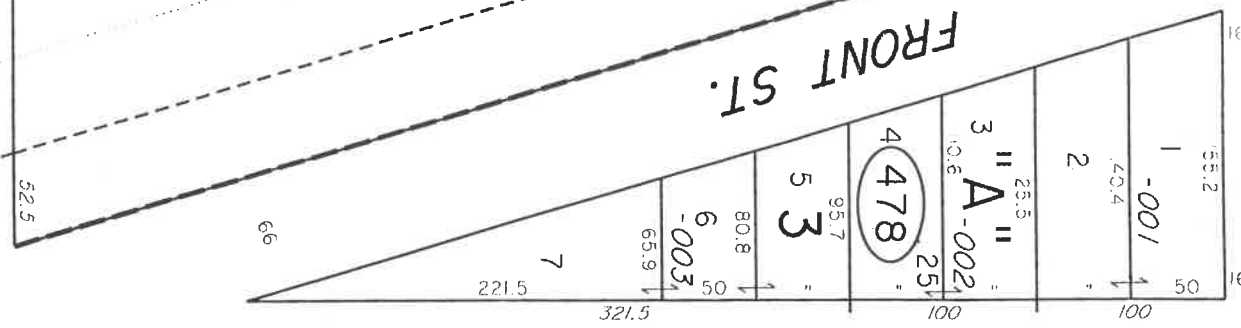

1st ST.

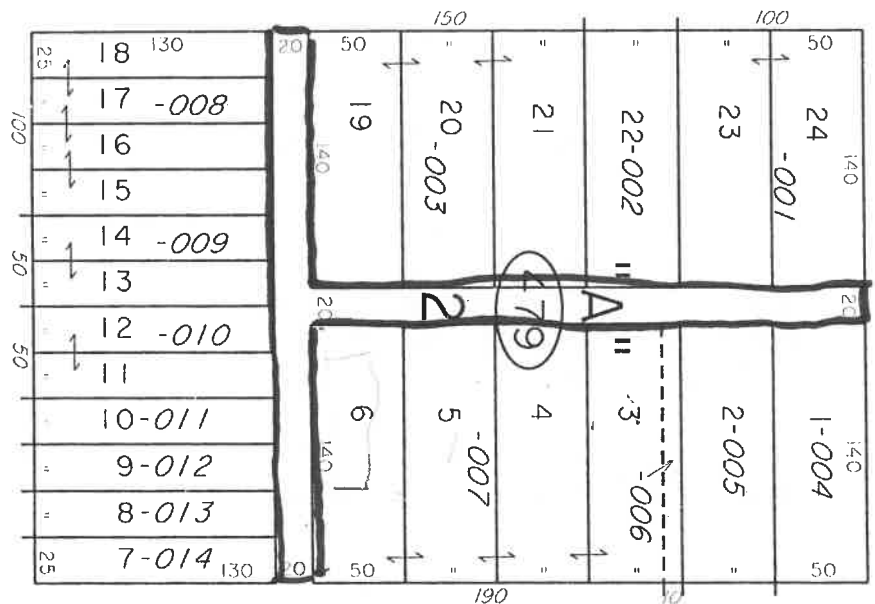

2nd ST.

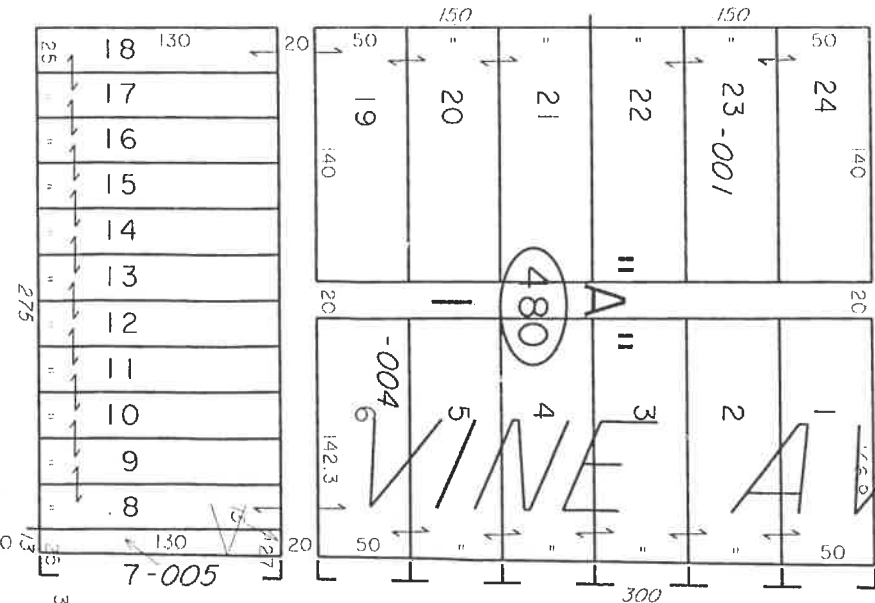

VINE AVE.

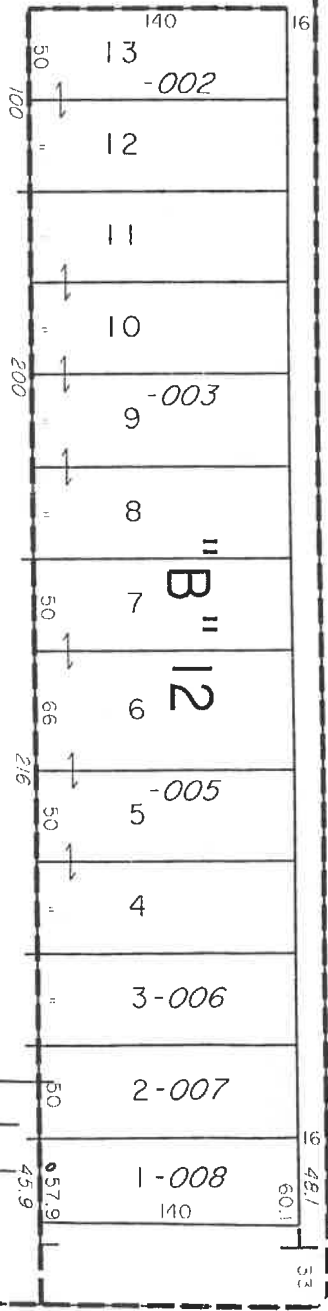

CLEVELAND ST.

49

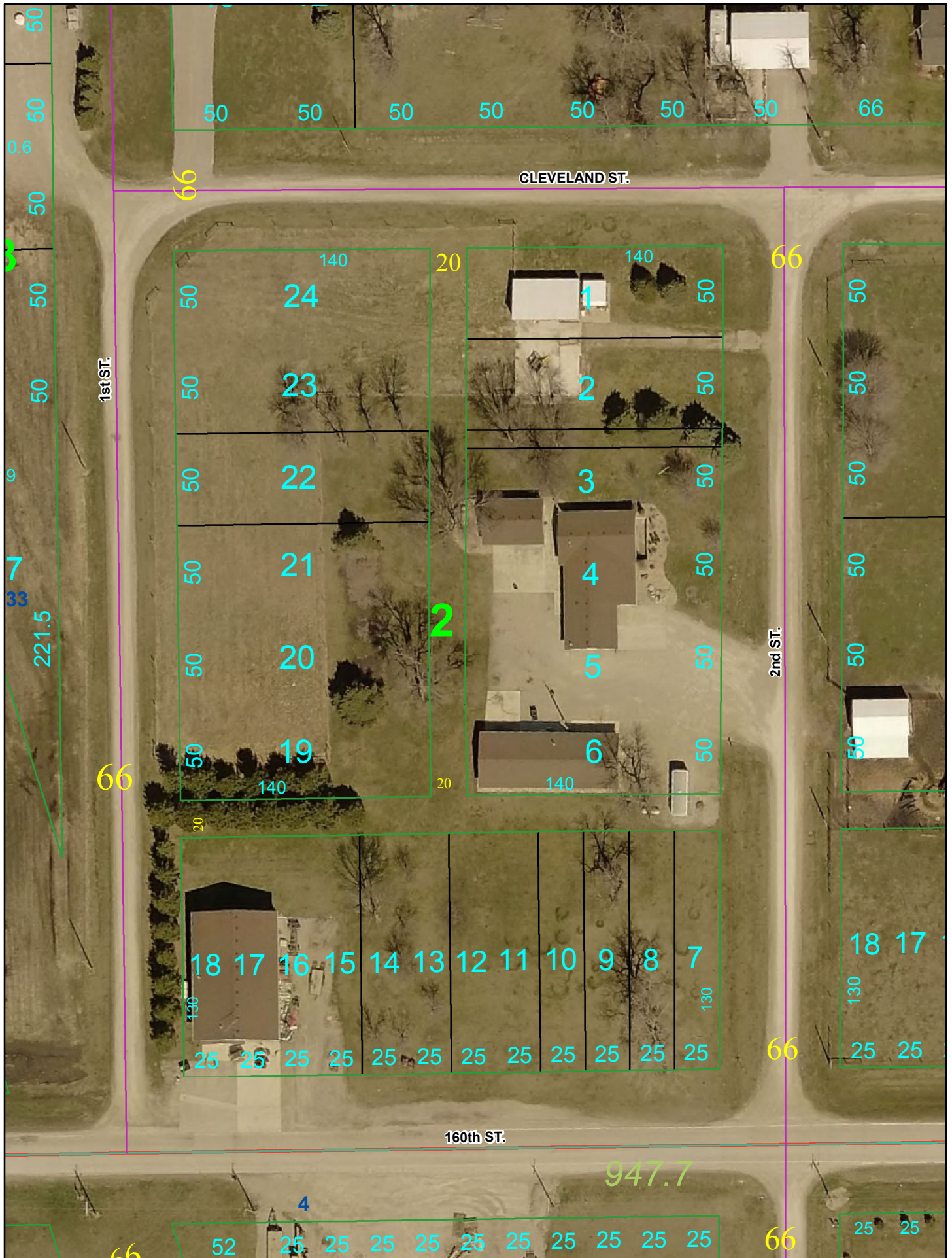

**Frank Hanig and Petitioners
20-Foot Wide Alley running through Block 2, Cartersville**

Figure 1

Looking west from 2nd Street along the 20-foot wide alley



March 20, 2019

Figure 2

Looking east from 1st Street along the 20-foot wide alley



March 20, 2019

Figure 3

Looking south from Cleveland Street along the 20-foot wide alley



March 20, 2019

Figure 4

Looking at the house on Lots 3-6



March 20, 2019

Figure 5

Looking at the utility building on Lots 1 and 2



March 20, 2019

Figure 6

Looking at the utility building on Lots 15-18



March 20, 2019

Figure 7

Looking west from 2nd Street, just south of Lot 6, Block 2, Cartersville (LP tank circled)



March 20, 2019